

PIPED CROSSING

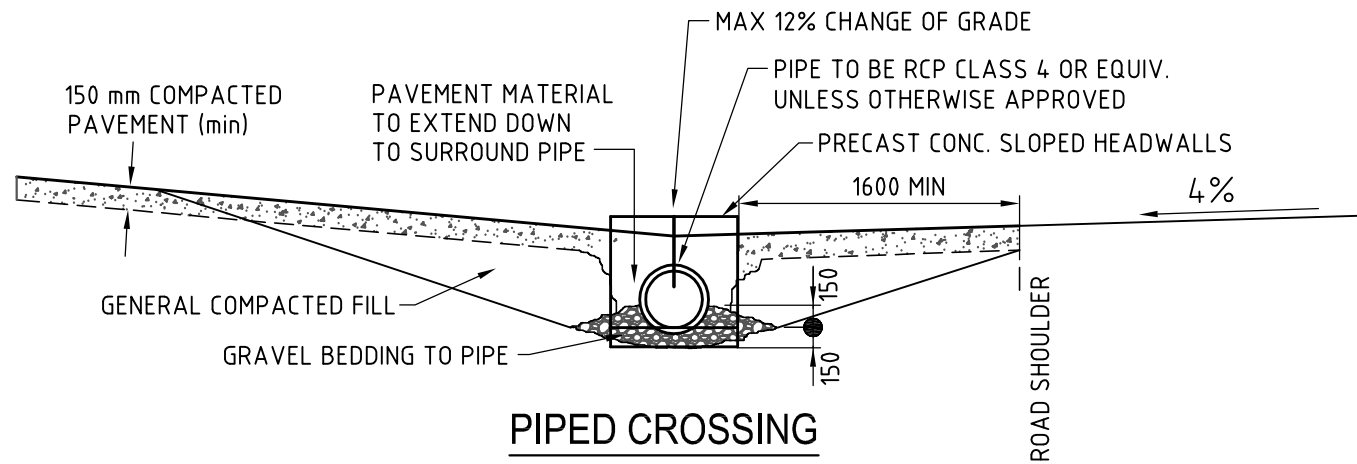

PIPED CROSSING

NOTES

1. WHERE EXISTING SERVICE ROAD IS SEALED, THE DRIVEWAY SHALL BE SEALED FROM THE EDGE OF ROAD TO A POINT 3000 INSIDE THE PROPERTY BOUNDARY. HOWEVER, ANY DRIVEWAY GREATER THAN 12% SHALL BE SEALED.
2. MAX CHANGE OF GRADE TO BE 12%, INCLUDING TRANSITION FROM ROAD. MAX GRADE OF DRIVEWAY TO BE 25%
3. GATES SHALL OPEN INTO THE PROPERTY WHERE POSSIBLE & BE SET BACK A MIN. OF 6.0m FROM THE ROAD SHOULDER. WHERE THE GATE MUST OPEN OUTWARDS, THE SETBACK SHALL BE INCREASED TO A MIN OF 10.0m FROM THE ROAD SHOULDER
4. SELF OPENING GATES MAY BE USED ON THE BOUNDARY
5. Q5 SWALE FLOWS SHALL BE BELOW THE SUBGRADE

NOT TO SCALE

B	ORIGINAL ISSUE	<i>[Signature]</i>	7/7/10
A	GENERALLY AMENDED	<i>[Signature]</i>	18/02/09
	REVISIONS	APP'D	DATE

STANDARD DRAWINGS

NORTHERN RIVERS LOCAL GOVERNMENT

DRIVEWAYS & VEHICULAR
CROSSINGS FOR ROADS
WITHOUT KERB & GUTTER
SLOPED HEADWALLS

ROAD/STREET
STANDARD
DRAWING

R-16

A	B		
---	---	--	--