

PLAN

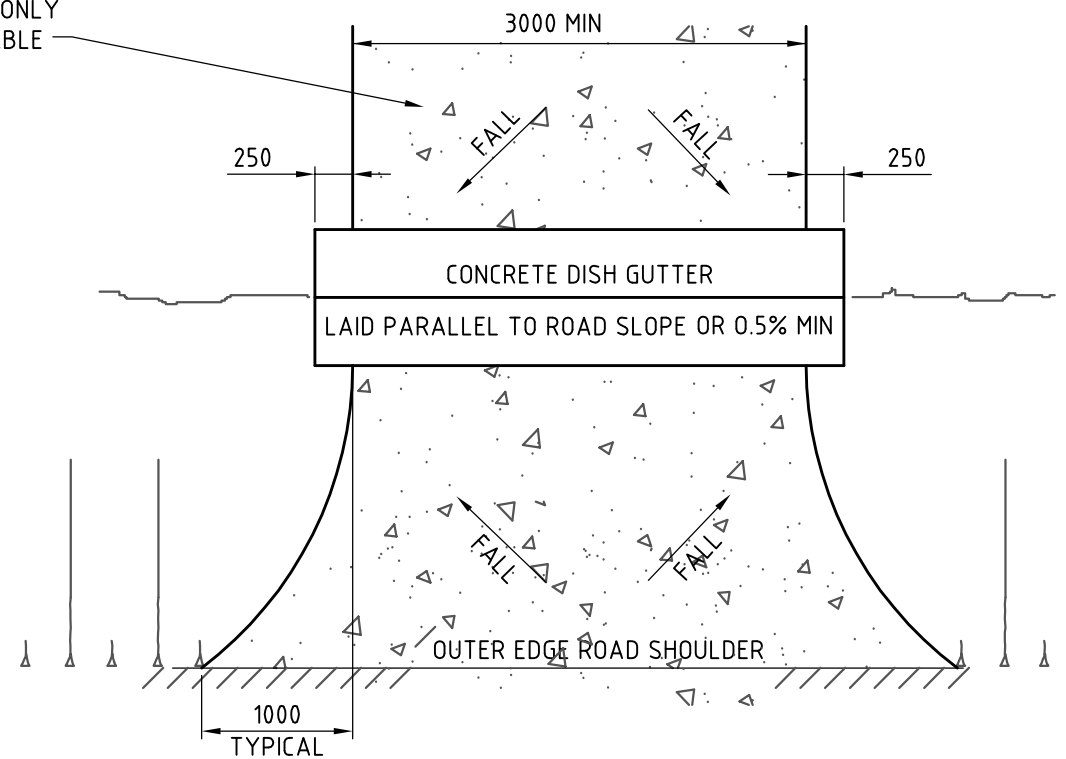

PLAN

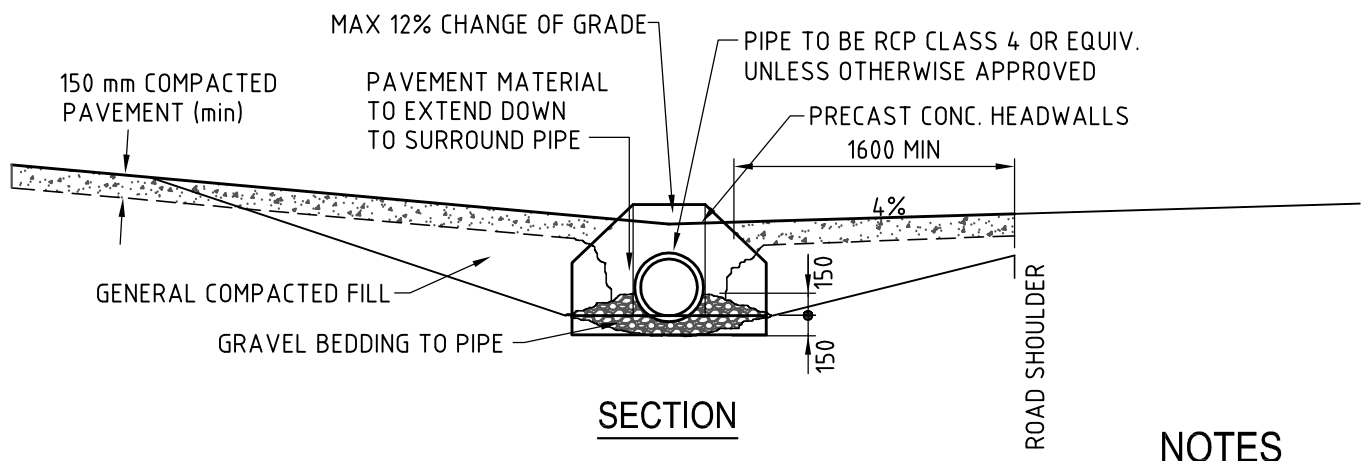

SECTION  
PIPED CROSSING

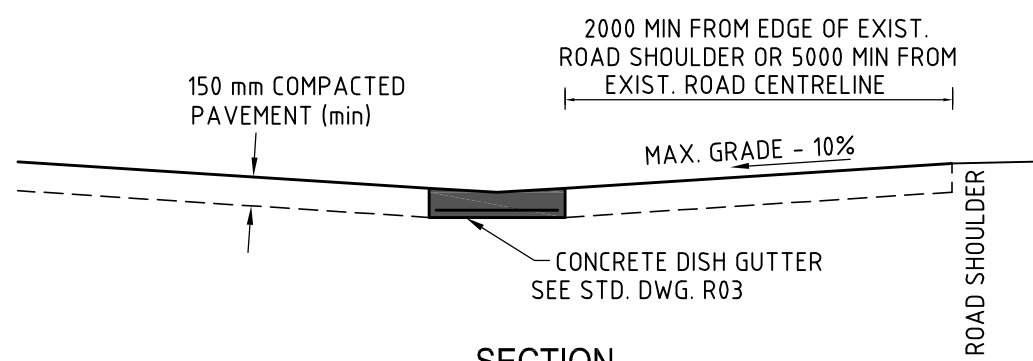

SECTION  
DISH CROSSING  
PREFERRED

NOTES

1. WHERE EXISTING SERVICE ROAD IS SEALED, THE DRIVEWAY SHALL BE SEALED FROM THE EDGE OF ROAD TO A POINT 3000 INSIDE THE PROPERTY BOUNDARY, OR GATE IF APPLICABLE. HOWEVER, ANY DRIVEWAY, OR PORTION OF DRIVEWAY, GREATER THAN 12% SHALL BE SEALED.
2. MAX CHANGE OF GRADE TO BE 12%, INCLUDING TRANSITION FROM ROAD. MAX GRADE OF DRIVEWAY TO BE 25%
3. GATES SHALL OPEN INTO THE PROPERTY WHERE POSSIBLE & BE SET BACK A MIN. OF 6.0m FROM THE ROAD SHOULDER. WHERE THE GATE MUST OPEN OUTWARDS, THE SETBACK SHALL BE INCREASED TO A MIN OF 10.0m FROM THE ROAD SHOULDER
4. SELF OPENING GATES MAY BE USED ON THE BOUNDARY
5. Q5 SWALE FLOWS SHALL BE BELOW THE SUBGRADE

NOT TO SCALE

C	CROSSFALL NOTE ADDED	<i>[Signature]</i>	18/6/2012
B	AMENDED	<i>[Signature]</i>	7/7/10
A	ORIGINAL ISSUE	<i>[Signature]</i>	3/10/06
	REVISIONS	APP'D	DATE

STANDARD DRAWINGS

# NORTHERN RIVERS LOCAL GOVERNMENT

DRIVEWAYS & VEHICULAR  
CROSSINGS FOR  
NON KERBED ROADS

ROAD/STREET  
STANDARD  
DRAWING  
**R-14**

A B C