

RURAL OR RURAL-RESIDENTIAL ROAD (CROWNED)

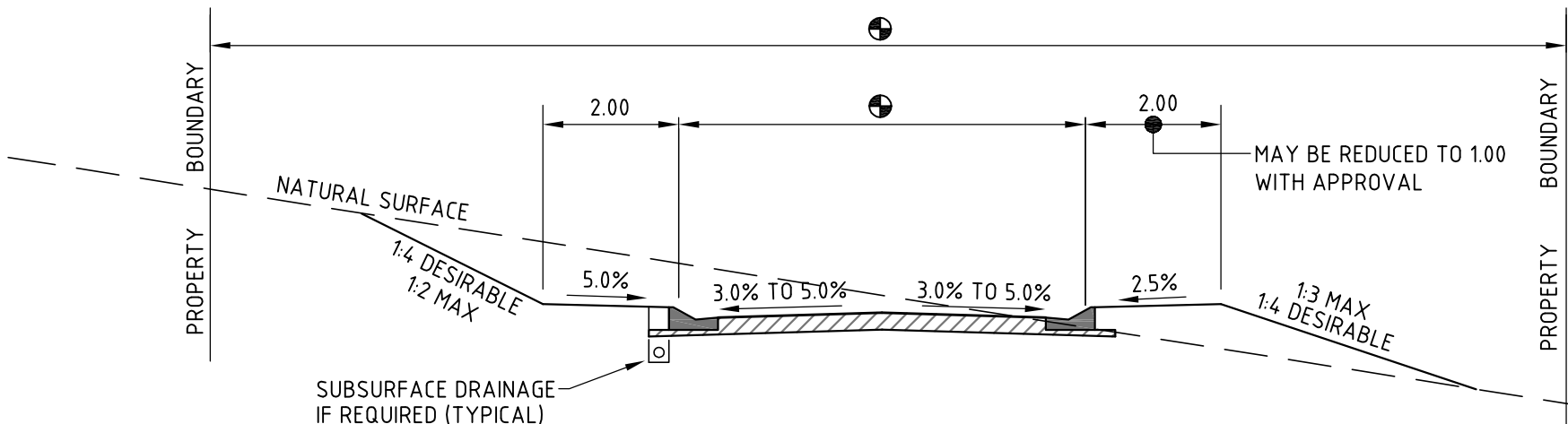

RURAL-RESIDENTIAL ROAD WITH KERB & GUTTER

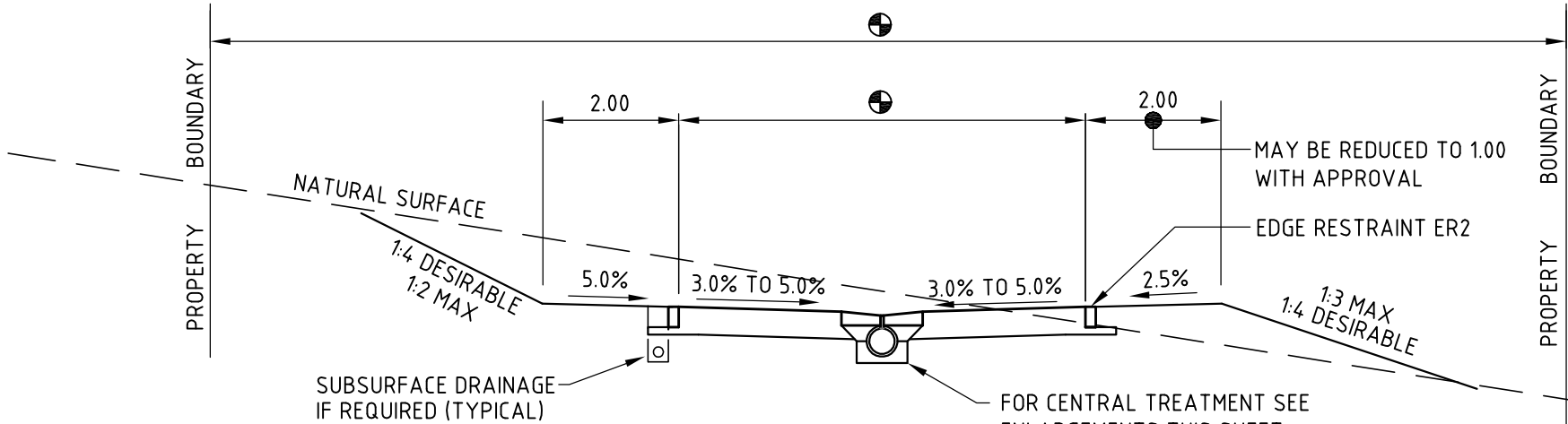

RURAL-RESIDENTIAL ROAD (DISHED)

LEGEND

⊕ VARIES - REFER SPEC. D1

NOTES

1. TABLE DRAINS STEEPER THAN 5% SHOULD HAVE EROSION PROTECTION MEASURES INSTALLED.
2. CUT BATTER SLOPES MAY BE VARIED ON SITE TO ENSURE LONG TERM STABILITY OF BATTERS.
3. UNSEALED ROADS SHALL BE DESIGNED USING PARAMETERS SET OUT IN NORTHERN RIVERS LOCAL GOVERNMENT DEVELOPMENT & DESIGN MANUAL
4. FOR PAVEMENT DESIGN REQUIREMENTS REFER TO NORTHERN RIVERS LOCAL GOVERNMENT DEVELOPMENT & DESIGN MANUAL
5. ALL DIMENSIONS IN METRES UNLESS SHOWN OTHERWISE.
6. SUBSOIL DRAINS MAY BE REQUIRED. - REFER TO DWG. R-09 FOR DETAILS.

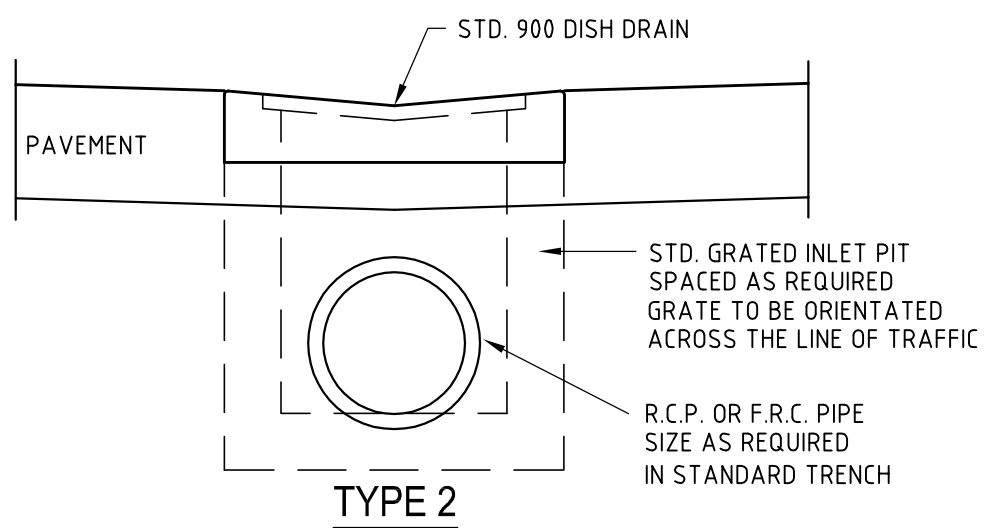
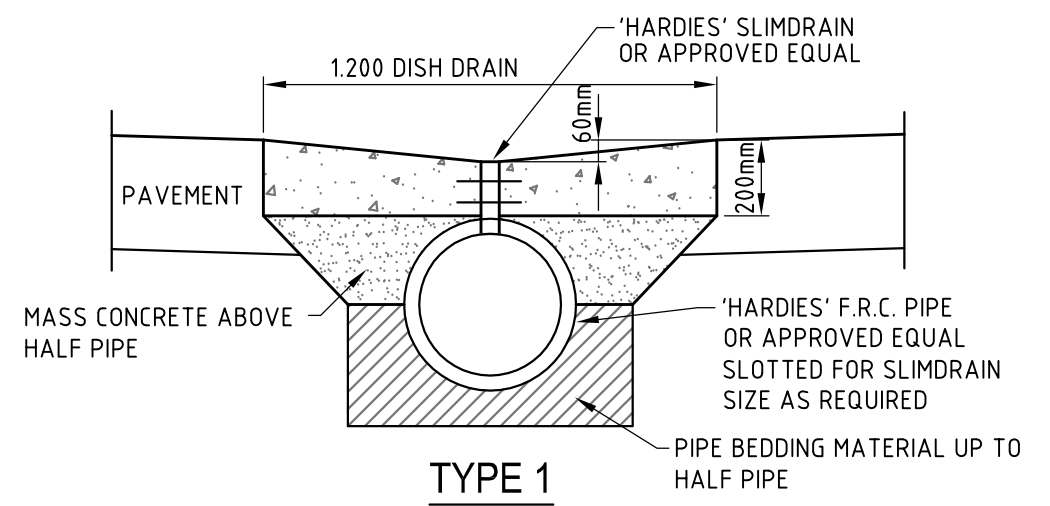

CENTRAL DRAINAGE TREATMENTS

NOT TO SCALE

B	TABLE DRAIN WATER SURFACE LEVEL CLARIFIED	<i>[Signature]</i>	7/7/10
A	ORIGINAL ISSUE	<i>[Signature]</i>	3/10/06
	REVISIONS	APP'D	DATE

STANDARD DRAWINGS

NORTHERN RIVERS LOCAL GOVERNMENT

TYPICAL CROSS SECTIONS
RURAL & RURAL RESIDENTIAL ROADS

ROAD/STREET
STANDARD
DRAWING
R-13

A	B		
---	---	--	--